

## Cryptic activity within the Type III<sub>1</sub> domain of fibronectin regulates tissue inflammation and angiogenesis

Christina Cho, Rhiannon Kelsh-Lasher, Anthony Ambesi and Paula J. McKeown-Longo\*

Center for Cell Biology & Cancer Research, Albany Medical College, 47 New Scotland Avenue, Albany, New York 12208, USA.

### ABSTRACT

The fibronectin matrix provides mechanical and biochemical information to regulate homeostatic and pathological processes within tissues. Fibronectin consists of independently-folded modules termed Types I, II and III. In response to cellular contractile force, Type III domains unfold to initiate a series of homophilic binding events which result in the assembly of a complex network of intertwining fibrils. The unfolding of Type III modules provides elasticity to the assembled fibronectin matrix allowing it to function as a dynamic scaffold which provides binding sites for cellular receptors, growth factors and other matrix molecules. Access to bioactive sites within the fibronectin matrix is under complex regulation and controlled through a combination of mechanical and proteolytic activity. Mechanical unfolding of Type III modules and limited proteolysis can alter the topographical display of bioactive sites within the fibronectin fibrils by exposing previously cryptic sites and disrupting functional sites. In this review we will discuss cryptic activity found within the first Type III module of fibronectin and its impact on tissue angiogenesis and inflammation.

**KEYWORDS:** fibronectin, matrix assembly, Toll-like receptor, VEGF, Type III domain, anastellin, inflammation, angiogenesis

### INTRODUCTION

Fibronectin is a high molecular weight, dimeric glycoprotein which is found in a soluble

protomeric form in the blood plasma and as an insoluble polymer in the extracellular matrix [1, 2]. Fibronectin is synthesized by the liver and found in the plasma at 400 µg/ml where it functions as a reservoir for tissue fibronectin [3, 4]. Fibronectin consists of independently-folded modules termed Types I, II and III. Polymerization of fibronectin into the matrix is a cell-dependent process and depends on the amino terminal five Type I modules which comprise the matrix assembly domain (Fig. 1). Fibronectin regulates basic cellular processes such as cell adhesion, migration, growth and survival, thus serving important roles in development, angiogenesis and wound repair [5, 6]. Fibronectin is also secreted by most cell types in response to injury and in association with disease states [7-13]. Cellular synthesized fibronectin is characterized by the inclusion of additional Type III modules termed extra domains A (EDA) and B (EDB) which arise through alternative splicing [14]. Polymerized fibronectin both regulates the composition of the matrix by providing binding sites for other matrix proteins and functions as a scaffold to sequester growth factors and associated proteins [15, 16]. Fibronectin associates with cells through interactions with integrin receptors. The primary integrin interacting with fibronectin is the  $\alpha_5\beta_1$  integrin, which binds the arginine-glycine-aspartic acid (RGD) sequence and synergy sites within the III<sub>9</sub>-III<sub>10</sub> modules (Fig. 1). This integrin mediates fibronectin polymerization and bi-directionally transduces both mechanical and biochemical information between the cells and the matrix. In the adult, estimates of the turnover of tissue fibronectin suggest a half-life of approximately

---

\*Corresponding author: mckeowp@mail.amc.edu

3 days [17, 18]. The fibronectin matrix is therefore a dynamic structure which is in a continual state of remodeling. Dysregulation of fibronectin homeostasis contributes to tissue pathologies such as inflammation and fibrosis. The availability of bioactive sites within the fibronectin matrix is under complex regulation and controlled through a combination of mechanical and proteolytic activity. In this review, we discuss the role of cryptic activities within the first Type III module in fibronectin fibrillogenesis and in the regulation of tissue angiogenesis and inflammation.

### **The III<sub>1</sub> module of fibronectin is a homophilic binding site involved in fibronectin matrix assembly**

Polymerization of fibronectin is a cell-dependent process driven by cellular contractile force which unmask cryptic homophilic binding sites required for fibrillogenesis. Exposure of these sites is under strict control to prevent inappropriate aggregation of fibronectin within the blood plasma. Early studies on purified plasma fibronectin documented a propensity for self-aggregation [19, 20] leading to the hypothesis that the insoluble matrix represented the biologically active form [21]. The self-association activity of fibronectin could also be demonstrated using heparin or denaturants [22-24], consistent with conformational changes within the molecule exposing the homophilic binding sites that control the aggregation of fibronectin into higher-order multimers. These *in vitro* formed fibronectin multimers exhibited functional characteristics distinct from the protomeric fibronectin monomer, providing the first evidence that the organization of fibronectin into fibrils could alter its biological activity [25]. To understand the process of fibronectin matrix assembly, early studies on the structure-function of fibronectin were focused on the identification of self-association sites in fibronectin which mediated fibrillogenesis. Limited proteolysis of plasma fibronectin using chymotrypsin led to the identification of a 14 kD heparin-binding fragment adjacent to the collagen binding site as a region involved in self-association [26, 27]. This fragment spanned the carboxy and amino terminal regions of the III<sub>1</sub> and III<sub>2</sub> modules (Fig. 1) and inhibited fibronectin matrix assembly by directly binding to fibronectin and preventing fibronectin

self-association [28]. Together these studies provided support for the involvement of the III<sub>1</sub> module in fibronectin fibrillogenesis. Additional support for a role for this region in matrix assembly was demonstrated in studies showing that two monoclonal antibodies (L8 and 9D2) directed at epitopes within the III<sub>1</sub> module inhibited the assembly of soluble fibronectin into extracellular matrix fibrils [29-31]. Subsequent studies using recombinant modules of fibronectin identified the homophilic binding partner for III<sub>1</sub> as fibronectin's amino terminal matrix assembly domain. Thermal denaturation of the recombinant III<sub>1</sub> module was shown to expose a high affinity binding site for both the 70 kD and 25 kD amino-terminal proteolytic fragments of fibronectin representing the matrix assembly domain [32]. A second study demonstrated that both intact fibronectin and the 70 kD amino-terminal fragment could bind to recombinant fusion proteins containing the III<sub>1</sub>/III<sub>2</sub> domains, suggesting that the binding site for 70 kD spanned both modules [33]. Subsequent mutational analysis showed that the I<sub>4</sub> and I<sub>5</sub> modules within the matrix assembly domain were required for the interaction between the matrix assembly domain and the III<sub>1</sub> module [34]. These studies all pointed to the interaction between III<sub>1</sub> and the amino terminal I<sub>1-5</sub> modules as a critical homophilic binding event in the assembly of the fibronectin matrix.

The Type III modules of fibronectin consist of approximately 90 amino acids organized into a folded beta sandwich structure (Fig. 2). In response to cellular contractile force, Type III modules unfold allowing fibronectin fibers to stretch up to several times their length [35, 36]. Cell-derived contractile force and substrate rigidity work together to regulate the polymerization of soluble fibronectin by controlling the accessibility of homophilic sites [37, 38]. Mediators which stimulate the cell's contractile apparatus such as TGF- $\beta$  or lysophosphatidic acid (LPA) increase the assembly of soluble fibronectin into the extracellular matrix [39-42]. The generation of forces required for the unfolding of fibronectin Type III modules depends on cytoskeletal-driven contraction which is transduced to the matrix through integrin adhesion receptors. This mechanical coupling of integrin to fibronectin matrix depends on the cytoskeleton and an activated  $\alpha_5\beta_1$  integrin

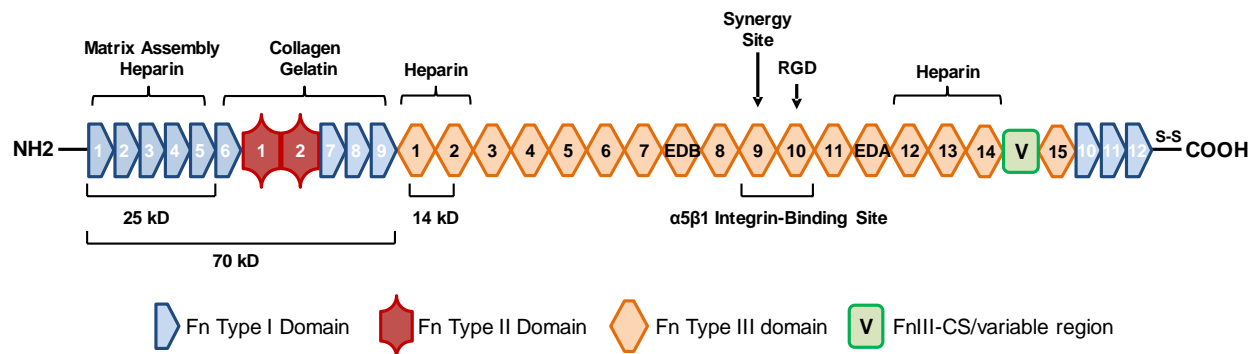

**Fig. 1. Fibronectin structure.** Fibronectin is a 450 kD dimeric multimodular extracellular matrix protein consisting of three repeating modules termed Types I, II and III. Each subunit contains 12 Type I (▢), 2 Type II (◆), and 15 Type III modules (◇). Additionally, there are two alternatively spliced Type III domains, EDB and EDA, as well as variable (V) region. The two subunits are joined by a disulfide bond (S-S) at the carboxy terminus. Alternative splicing of a single pre-mRNA can generate multiple isoforms including or excluding the EDB and EDA modules and the variable region can also be entirely spliced out, entirely spliced in, or partially spliced out. Its multi-modular structure and inter-modular regions allow for the flexibility of the fibronectin molecule and regulates its function. The fibronectin molecule contains sites for self-assembly, integrin-receptor ligation and other matrix proteins. Binding sites for collagen, heparin and the  $\alpha_5\beta_1$  integrin are shown. The matrix assembly site was localized to the N-terminal domain via the production of proteolytic fibronectin fragments 25 kD and 70 kD. The 14 kD chymotryptic fragment contains a self-association site involved in matrix assembly.

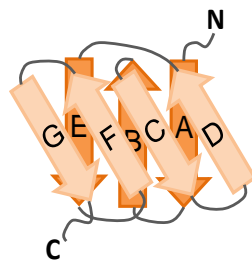

**Fig. 2. Secondary structure of a Type III domain.** The Type III modules of fibronectin are structurally characterized by seven anti-parallel beta strands in two separate beta sheets arranged into a beta sandwich. Beta strands A, B and E form one sheet which is packed against the second beta sheet containing strands C, D, F and G.

[38, 43-45]. Mechanical stretching of fibronectin results in the exposure of cryptic binding sites for the amino-terminal matrix assembly domain which are blocked by the L8 monoclonal antibody directed at the III<sub>1</sub> module [46]. These data suggest that cellular contractile force regulates fibrillogenesis by controlling the availability of homophilic binding sites within the assembling fibronectin molecules.

The exposure of the cryptic self-association activity within the III<sub>1</sub> module may be regulated through

an association with the neighboring III<sub>2</sub> module. III<sub>1-2</sub> and isolated III<sub>2</sub> bind to the amino-terminal matrix assembly domain of fibronectin weakly in their native forms; however, in its open conformation, III<sub>1-2</sub> binds almost irreversibly to the 70 kD fragment [47, 48], consistent with the interaction between III<sub>1</sub> and III<sub>2</sub>, controlling the high affinity binding between I<sub>1-5</sub> and III<sub>1</sub>. Recent images of fibronectin fibers in cultured cells using single-molecule localization microscopy are consistent with fibril formation being mediated by a substantial N-terminal overlap, which allows for an interaction between the III<sub>1-2</sub> modules of one molecule and the I<sub>4-5</sub> modules of the adjacent molecule [49]. Thus, the data suggests a model whereby fibrillogenesis depends on a high affinity interaction between III<sub>1</sub> and I<sub>4-5</sub> which is regulated by cellular contractile force (Fig. 3).

The III<sub>1</sub> module also associates with other Type III modules [50, 51] including III<sub>10</sub>, which contains the RGD sequence required for integrin binding [50]. The binding of III<sub>10</sub> to III<sub>1</sub> was shown to be conformation-dependent and required the unfolding of III<sub>10</sub>. Once unfolded, III<sub>10</sub> promoted the fibrillogenesis of intact fibronectin into high molecular mass multimers. The formation of these multimers occurred in the absence of cells but

required the III<sub>1</sub> and the amino-terminal I<sub>1-5</sub> modules [50]. Predictions based on steered molecular dynamics described a mechanical unfolding profile for III<sub>10</sub> which resulted in the exposure of hydrophobic regions within the N-terminal  $\beta$ -strands A and B [52]. Subsequent studies identified a sequence SLLISWD within the B strand that promoted the aggregation of fibronectin in the absence of cells. This 7-amino acid ‘multimerization sequence’ could also stimulate the assembly of matrix fibronectin in cultured fibroblasts [53]. These data suggest that fibronectin fibrillogenesis depends on the regulated exposure of cryptic homophilic binding sites within Type III modules.

### **Anastellin: Anti angiogenic activity within III<sub>1</sub> module**

Studies using a series of peptides derived from the 14 kD homophilic binding chymotryptic fragment of fibronectin, identified a region in the III<sub>1</sub> module which binds to fibronectin and stimulates fibronectin polymerization in the absence of cells. The 76 amino acid peptide represented the carboxy-terminal two thirds of the III<sub>1</sub> module and was designated III<sub>1c</sub> (Fig. 4). The *in vitro* fibronectin polymerized by III<sub>1c</sub> was found to be more adhesive than the fibronectin matrix assembled by fibroblast cells, and hence it was termed ‘superfibronectin’ [28]. Subsequent analysis using various recombinant modules of fibronectin identified III<sub>1-3</sub> and III<sub>11</sub> as III<sub>1c</sub> binding sites involved in the formation of *in vitro* fibronectin aggregates [54-56]. The formation of these *in vitro* multimers by III<sub>1c</sub> was thought to depend on intermolecular  $\beta$ -strand exchange between unfolded modules [54, 57].

*In vivo* studies in mouse xenograft models identified III<sub>1c</sub> as having anti-tumor activity. Intraperitoneal injections of either III<sub>1c</sub> or superfibronectin were found to inhibit the growth and metastasis of several human tumors in mouse models of experimental and spontaneous metastasis [58]. Blood vessel density in tumors of mice treated with III<sub>1c</sub> was reduced compared to untreated controls, suggesting that III<sub>1c</sub> was inhibiting tumor angiogenesis. Based on its anti-angiogenic properties, III<sub>1c</sub> was then termed ‘anastellin’ derived from the Greek word ‘to retreat’. The anti-angiogenic activity of anastellin required plasma fibronectin as tumors implanted in mice lacking plasma fibronectin

were unaffected by anastellin, suggesting that complexing with fibronectin in the plasma was required for anastellin’s inhibitory activity [59]. As plasma fibronectin is continuously deposited in the tissue matrix, anastellin’s dependence on plasma fibronectin for activity may reflect a requirement for plasma fibronectin to target and concentrate anastellin within tissues undergoing matrix remodeling [4].

Early studies done to address the molecular mechanism underlying the inhibition of angiogenesis by anastellin indicated that anastellin inhibited cell growth. These effects were proposed to result from an anastellin-mediated disassembly of the established fibronectin matrix, leading to a loss of actin stress fibers, activation of p38 mitogen-activated protein (MAP) kinase and an inhibition of the cell cycle [60]. Studies on human microvessel endothelial cells confirmed the inhibitory effects of anastellin on cell growth. These studies demonstrated that anastellin selectively inhibited serum-dependent extracellular signal regulated kinase (ERK) signaling and prevented G1/S phase transition in endothelial cells, while having little effect on the growth of other cell types [61]. In addition, anastellin also inhibited ERK activation in response to the lysophospholipids LPA and S1P. These phospholipids regulate growth, migration and stress fiber formation through G-protein dependent activation of the ERK, PI3K and Rho pathways, respectively. Interestingly, anastellin inhibited only the ERK/growth pathway while having no effect on migration or stress fiber formation, consistent with anastellin specifically inhibiting only the ERK arm of the lysophospholipid signaling pathway [62]. A subsequent quantitative study looking at the effect of anastellin on the established fibronectin matrix found that in contrast to the earlier study [60], treatment of cells with anastellin did not result in any decrease in the amount of matrix fibronectin. Rather, anastellin caused a rapid conformational remodeling of fibronectin within the assembled fibrils which could be detected as a selective loss of antibody epitopes [63]. A more recent study has now shown that the antiangiogenic activity of anastellin is linked to anastellin-mediated changes in the topography of the fibronectin matrix which result in loss of the synergy site within the III<sub>9</sub> module

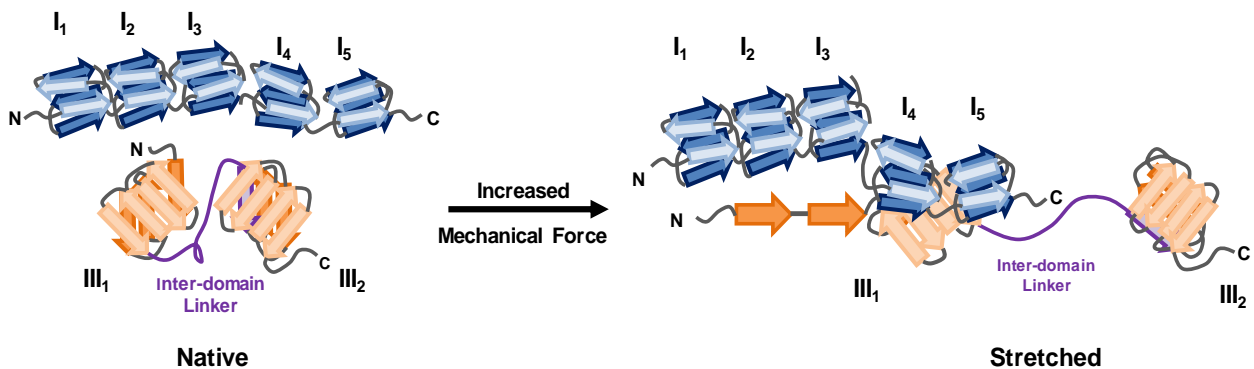

**Fig. 3. Unfolding of III<sub>1-2</sub> promotes high affinity binding of I<sub>4-5</sub> during matrix assembly.** A self-association site required for matrix assembly was isolated to the III<sub>1</sub> and III<sub>2</sub> domains which are connected by a flexible inter-domain linker. Unlike other Type III domains, the A-strand of III<sub>2</sub> is disordered in solution and is included in the inter-domain linker. In the native conformation, there is a weak association between the III<sub>1-2</sub> and I<sub>1-5</sub> amino-terminal modules. In response to mechanical force, III<sub>1-2</sub> is stretched into a more open conformation to unmask a high affinity binding site for I<sub>4-5</sub>.

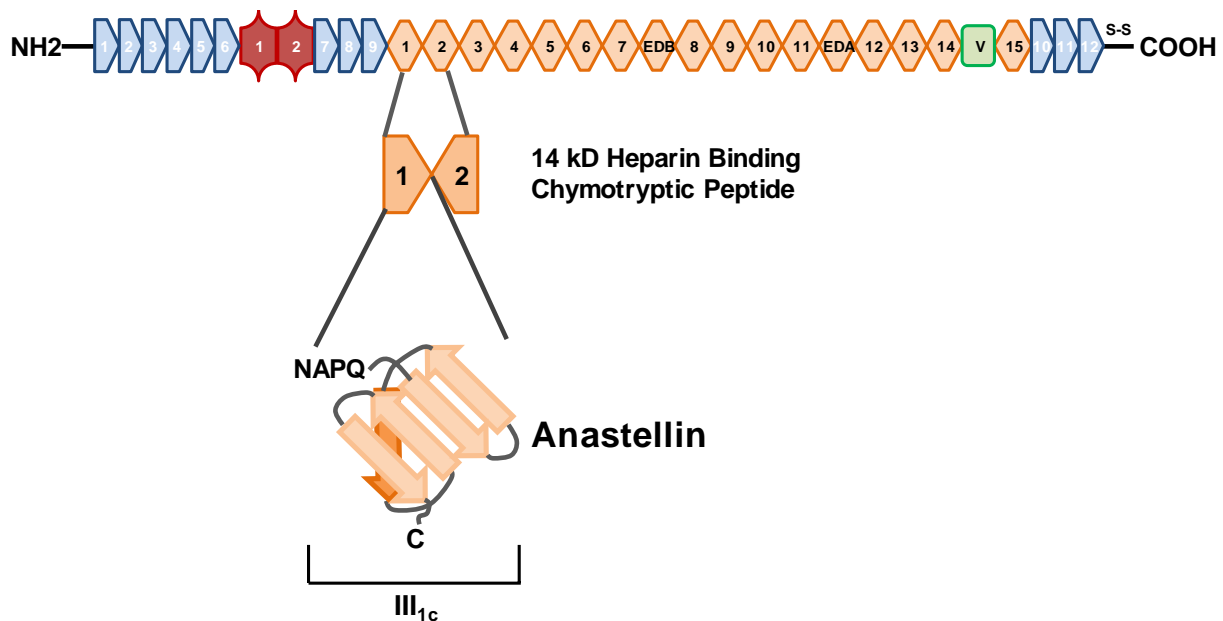

**Fig. 4. The derivation of anastellin (III<sub>1c</sub>) from the first Type III domain of fibronectin.** Proteolysis of fibronectin using chymotrypsin releases a 14 kD heparin-binding fragment. This fragment begins within the III<sub>1</sub> module and extends into the III<sub>2</sub> module. It inhibits fibronectin matrix assembly by binding directly to fibronectin and blocking self-association. Studies evaluating a series of peptides derived from the 14 kD fragment identified a region in the III<sub>1</sub> module which stimulated fibronectin polymerization in the absence of cells. This 76 amino acid peptide has the amino-terminal sequence asparagine-alanine-proline-glutamine (NAPQ) and is derived from the carboxy-terminal two thirds of the III<sub>1</sub> module. This peptide was designated III<sub>1c</sub> and named anastellin.

and an inactivation of the  $\alpha_5\beta_1$  integrin [64]. The synergy site is known to regulate the bond strength between  $\alpha_5\beta_1$  and fibronectin [65, 66]. The effect of anastellin was specific to the  $\alpha_5\beta_1$  integrin as ligation

of the  $\alpha_v\beta_5$  integrin and the number of adhesion sites were unaffected. Integrin inactivation was accompanied by an inhibition of vascular endothelial growth factor (VEGF) signaling which was specific

to the 165 isoform of VEGF (VEGF165). Anastellin did not inhibit signaling in response to either VEGF121 or EGF. The inhibitory effect of anastellin on VEGF165 was due to the inability of the cells to assemble the complex between the VEGF receptor and neuropilin which is required for VEGF165 signaling. The data suggest a model whereby anastellin-mediated changes in the topographical display of  $\alpha_5\beta_1$  integrin binding sites within the established fibronectin matrix specifically impact signaling pathways regulated by the  $\alpha_5\beta_1$  integrin (Fig. 5). These data also suggest that homophilic binding peptides of fibronectin may have applications in the design of engineered tissue scaffolds by reprogramming the cellular response to growth factors.

### **III<sub>1c</sub> as a ligand for Toll-like receptors**

Invading pathogens (Pathogen Associated Molecular Patterns, PAMPs) or endogenous molecules released following tissue damage (Damage Associated Molecular Patterns, DAMPs) promote inflammation by activating Toll-like receptors (TLRs), a family of receptors which regulate the NF $\kappa$ B-dependent synthesis of cytokines. Extracellular matrix-derived products of tissue injury including proteoglycans, hyaluronic acid, Tenascin C and the EDA isoform of fibronectin have been proposed as ligands for the TLR4 receptor [67]. The EDA isoform of fibronectin is synthesized in response to tissue injury and has been shown to activate TLR4 signaling in a variety of cell types [68-71]. In addition, EDA<sup>+</sup> fibronectin has been shown to promote both chronic inflammation and fibrosis in several disease models [72-76]. Recent studies have identified III<sub>1</sub> as a second fibronectin domain which activates TLR4 [71, 77]. Addition of the III<sub>1c</sub> peptide to human fibroblasts induced the TLR4-dependent nuclear translocation of NF $\kappa$ B and induced robust expression of a select group of pro-inflammatory cytokines. Most notably, expression of the cytokines CXCL1, -2, -3, IL-8 and TNF- $\alpha$  were found to be highly upregulated in response to III<sub>1c</sub> [71, 77]. The role of III<sub>1c</sub> as a DAMP was further evaluated in studies designed to understand the effects of p38 MAP Kinase activation via this region of fibronectin. Earlier studies had shown that III<sub>1c</sub> activated p38 in fibroblast cells [60, 63].

The p38 MAP Kinase pathway is well-documented as being a downstream effector of TLR4 and the activation of p38 by III<sub>1c</sub> in human dermal fibroblasts was found to be dependent on TLR4. Inhibitors of p38 kinase activity and its downstream target MAPKAP Kinase2 (MK2) resulted in a significant decrease in III<sub>1c</sub>-induced cytokine expression through effects on cytokine message stability [71]. Studies using human lung fibroblasts showed that III<sub>1c</sub> induced expression of similar pro-inflammatory cytokines through the activation of TLR2, suggesting that III<sub>1c</sub> may serve as an agonist for both TLR2 and TLR4 [78]. A comparative study between EDA and III<sub>1c</sub> showed that each module induced an identical inflammatory gene signature in dermal fibroblasts. Additionally, each module induced comparable amounts of the IL-8 cytokine, which was sensitive to inhibitors of NF $\kappa$ B, p38 and MK2 as well as the blocking antibody to TLR4. Surprisingly, when cells were treated with both modules, the amount of IL-8 secreted was eight times greater than the expected additive effect, indicating that the modules worked synergistically to induce cytokine expression [71]. The synergy between the two modules suggests that injury-induced expression of EDA<sup>+</sup> fibronectin by tissue fibroblasts coupled with increased proteolysis of matrix may allow fibroblasts within the site of injury to mount a rapid and robust release of cytokines in response to tissue damage.

Currently, the physiological conditions required for the manifestation of TLR4 agonist activity within the III<sub>1</sub> module are not known, but likely arise through a change in the balance of mechanical forces or active proteases. As described above, the III<sub>1</sub> module is under mechanical regulation. Increases in myofibroblasts within wounded tissue would be expected to increase contractile forces in the tissue. Fibronectin fragments generated during proteolytic remodeling of matrix have also been documented in injured and diseased tissues [79-84]; however, very little is known about their specific sequences and concentrations within local microenvironments. Proteomic analysis has indicated that fibronectin cleavage at the amino acid site <sup>600</sup>NAPQ by MMP2 will effectively remove the first two beta strands from the III<sub>1</sub> domain [85], thereby creating the III<sub>1c</sub> structure which could either be released from the matrix by further

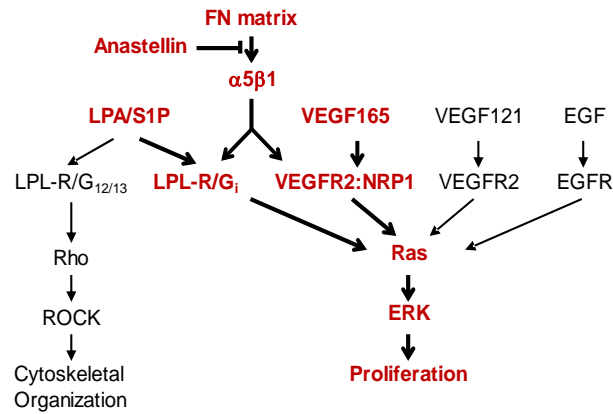

**Fig. 5. Identification of anastellin sensitive signaling pathways in endothelial microvessel cells.** Anastellin-mediated effects on matrix topography selectively inhibit growth factor and lysophospholipid (LPL) signaling to ERK (shown in red). Remodeling of the fibronectin matrix in response to anastellin causes an inactivation of the  $\alpha_5\beta_1$  integrin thereby disrupting LPA S1P and VEGF165 signaling. Anastellin inhibited the Lysophospholipid Receptor (LPL-R) activation of G<sub>i</sub> without affecting the activation of G<sub>12/13</sub>. Anastellin also inhibited VEGF165 signaling to ERK by inhibiting the formation of the VEGFR2/NRP complex. Anastellin had no effect on ERK activation in response to either VEGF121 or EGF.

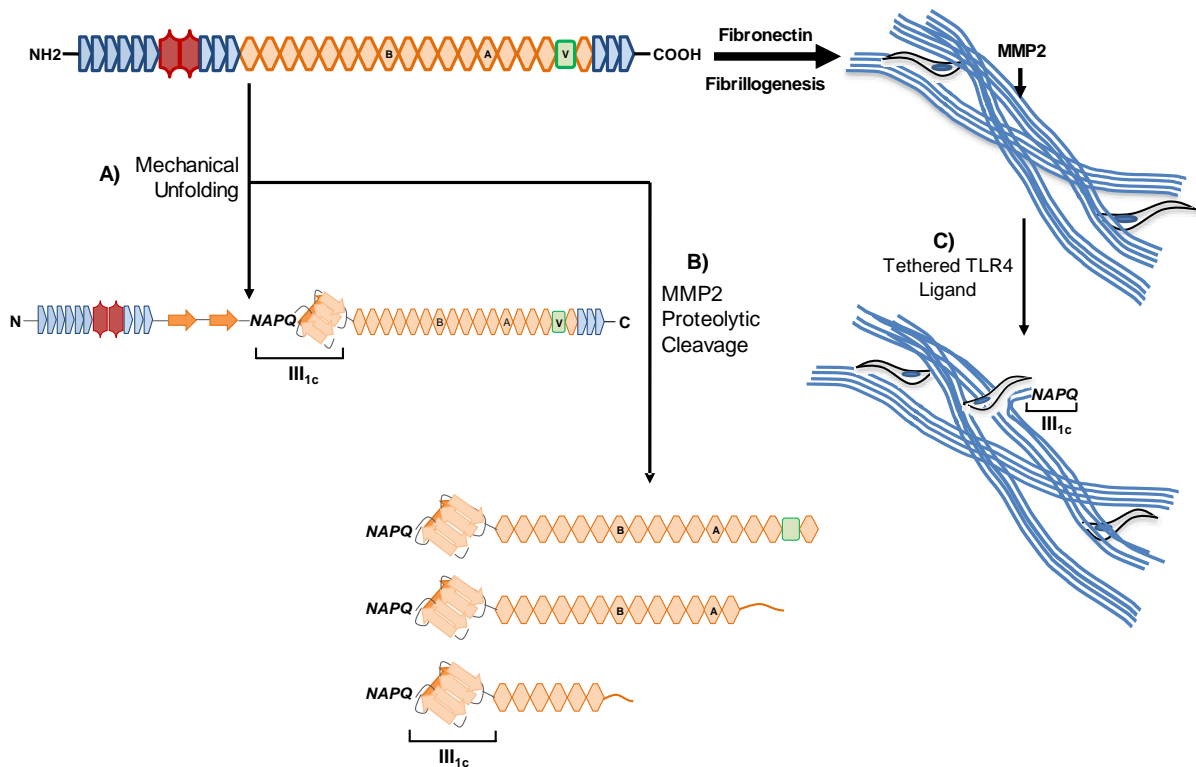

**Fig. 6. Unmasking of TLR4 agonist activity within the III<sub>1</sub> module by mechanical unfolding or MMP2-mediated cleavage of fibronectin fibers.** **A)** In response to cellular contractile force, the A and B strands of the III<sub>1</sub> module of fibronectin unfold to produce a stable intermediate structure which recapitulates III<sub>1c</sub>. **B)** Alternatively, the MMP2 cleavage sites within III<sub>1</sub> and along the length of the molecule will allow for the generation of various sized soluble fibronectin fragments whose amino-terminus contains III<sub>1c</sub> [85]. **C)** Limited proteolysis of fibronectin fibrils with MMP2 would be expected to release III<sub>1c</sub>-like structures which remain tethered to the fibril at the carboxyl end. Tethering would be expected to facilitate the localized increases in the concentration of TLR4 ligands.

proteolysis or remain tethered to the fibrils at the carboxyl end (Fig. 6). Tethering would provide a mechanism for the local concentration of III<sub>1c</sub> to reach biologically active ( $\mu$ M) amounts within a localized area. Ultraviolet absorption microscopy has estimated the density of fibronectin in a polymerized fibronectin fiber at 177 mg/ml [86], which corresponds to a concentration of 400  $\mu$ M within the fiber: a concentration that would be expected to increase as the fiber is placed under increased strain. Therefore, limited MMP-2 mediated proteolysis of the fiber has the potential to generate a high local concentration of fibronectin-derived DAMPs from the III<sub>1</sub> domain.

## CONCLUSION

Remodeling of the extracellular matrix occurs in response to tissue injury and during the course of many diseases. Dysfunctional remodeling of the matrix disrupts normal cell behavior which leads to a loss of tissue homeostasis, often resulting in chronic inflammation and fibrosis which left unchecked can lead to neoplasia and organ failure. While it is well accepted that fibronectin matrix fibrils contain cryptic biological activities, very little is known about how these activities are regulated. Homophilic binding peptides released from the matrix, associate with fibronectin fibrils and affect the pattern of ligated integrins. These findings suggest that reagents based on anastellin or other peptides (i.e., bacterial adhesins, anginex, dermatopontin) which have been demonstrated to bind to fibronectin and alter its conformation [87-90] may have useful applications for modulating the tissue microenvironment by specifically regulating the display of biologically active sites within the fibronectin matrix. The III<sub>1</sub> module can also serve as an agonist for TLR4. This activity is cryptic within III<sub>1</sub> and may be exposed through mechanical unfolding or proteolytic fragmentation. The impact of the III<sub>1</sub> and EDA modules of fibronectin on disease pathologies, such as inflammation and fibrosis, is just beginning to be understood [91]. Understanding the mechanisms controlling the interaction of these domains with TLR4 may prove to be helpful in therapeutically designing reagents to specifically target DAMP-mediated inflammation.

## ACKNOWLEDGEMENTS

This study was supported by NIH CA058626 to PM-L.

## CONFLICT OF INTEREST STATEMENT

There are no conflicts of interest.

## REFERENCES

1. Xu, J. and Mosher, D. 2011, Fibronectin and other adhesive glycoproteins. In *The Extracellular Matrix: An Overview* (R. P. Mecham (Ed.)), Springer-Verlag, 43-55.
2. To, W. S. and Midwood, K. S. 2011, Fibrogenesis Tissue Repair, 4, 21. doi: 10.1186/1755-1536-4-21.
3. Oh, E., Pierschbacher, M. and Ruoslahti, E. 1981, Proc. Natl. Acad. Sci., 78, 3218.
4. Moretti, F. A., Chauhan, A. K., Iaconcig, A., Porro, F., Baralle, F. E. and Muro, A. F. 2007, J. Biol. Chem., 282, 28057.
5. Schwarzbauer, J. E. and DeSimone, D. W. 2011, Cold Spring Harbor Perspectives in Biology, 3, 7.
6. Astrof, S. and Hynes, R. O. 2009, Angiogenesis, 12, 165.
7. Grinnell, F., Billingham, R. E. and Burgess, L. 1981, J. Invest. Dermatol., 76, 181.
8. Siri, A., Carnemolla, B., Castellani, P., Balza, E., Raffanti, S. and Zardi, L. 1983, Cancer Lett., 21, 117.
9. Clark, R. A., Quinn, J. H., Winn, H. J., Lanigan, J. M., DellaPella, P. and Colvin, R. B. 1982, J. Exp. Med., 156, 646.
10. Driscoll, K. E., Maurer, J. K., Poynter, J., Higgins, J., Asquith, T. and Miller, N. S. 1992, Toxicol. Appl. Pharmacol., 116, 30.
11. Sakai, T., Johnson, K. J., Murozono, M., Sakai, K., Magnuson, M. A., Weiloch, T., Cronberg, T., Isshiki, A., Erickson, H. P. and Fassler, R. 2001, Nat. Med., 7, 324.
12. Peters, J. H., Grote, M. N., Lane, N. E. and Maunder, R. J. 2011, Biomark Insights, 6, 59.
13. von Au, A., Vasel, M., Kraft, S., Sens, C., Hackl, N., Marx, A., Stroebel, P., Hennenlotter, J., Todenhöfer, T., Stenzl, A., Schott, S., Sinn, H. P., Wetterwald, A., Bermejo, J. L., Cecchini, M. G. and Nakchbandi, I. A. 2013, Neoplasia, 15, 925.



14. White, E. S. and Muro, A. F. 2011, *IUBMB Life*, 63, 538.
15. Dallas, S. L., Sivakumar, P., Jones, C. J. P., Chen, Q., Peters, D. M., Mosher, D. F., Humphries, M. J. and Kielty, C. M. 2005, *J. Biol. Chem.*, 280, 18871.
16. Emanuel, S. L., Engle, L. J., Chao, G., Zhu, R. R., Cao, C., Yaniuk, A. P., Hosbach, J., Brown, J., Fitzpatrick, E., Gokemeijer, J., Morin, P., Morse, B. A., Carvajal, I. M., Fabrizio, D., Wright, M. C., Das, G. R., Gosselin, M., Cataldo, D., Ryseck, R. P., Doyle, M. L., Wong, T. W., Camphausen, R. T., Cload, S. T., Marsh, H. N., Gottardis, M. M. and Furfine, E. S. 2011, *MAbs*, 3, 38.
17. Deno, D. C., Saba, T. M. and Lewis, E. P. 1983, *Am. J. Physiol.*, 245, R564-R575.
18. Thompson, C., Blumenstock, F. A., Saba, T. M., Feustel, P. J., Kaplan, J. E., Fortune, J. B., Hough, L. and Gray, V. 1989, *J. Clin. Invest.*, 84, 1226.
19. Yamada, K. M., Schlesinger, D. H., Kennedy, D. W. and Pastan, I. 1977, *Biochemistry*, 16, 5552.
20. Vaheri, A., Ruoslahti, E., Linder, E., Wartiovaara, J., Keski-Oja, J., Kuusela, P. and Saksela, O. 1976, *J. Supramol. Struct.*, 4, 63.
21. Hedman, K., Vaheri, A. and Wartiovaara, J. 1978, *J. Cell Biol.*, 76, 748.
22. Williams, E. C., Janmey, P. A., Johnson, R. B. and Mosher, D. F. 1983, *J. Biol. Chem.*, 258, 5911.
23. Richter, H., Wendt, C. and Hörmann, H. 1985, *Biol. Chem. Hoppe Seyler*, 366, 509.
24. Mosher, D. F. and Johnson, R. B. 1983, *J. Biol. Chem.*, 258, 6595.
25. Oberley, T. D., Murphy-Ullrich, J. E., Albrecht, R. M. and Mosher, D. F. 1983, *Exp. Cell Res.*, 145, 265.
26. Ehrismann, R., Chiquet, M. and Turner, D. C. 1981, *J. Biol. Chem.*, 256, 4056.
27. Ehrismann, R., Roth, D. E., Eppenberger, H. M. and Turner, D. C. 1982, *J. Biol. Chem.*, 257, 7381.
28. Morla, A. and Ruoslahti, E. 1992, *J. Cell Biol.*, 118, 421.
29. Chernousov, M. A., Faerman, A. I., Frid, M. G., Printseva, O. Yu. and Kotliansky, V. E. 1987, *FEBS Lett.*, 217, 124.
30. Chernousov, M. A., Fogerty, F. J., Kotliansky, V. E. and Mosher, D. F. 1991, *J. Biol. Chem.*, 266, 10851.
31. Fogerty, F. J., Akiyama, S. K., Yamada, K. M. and Mosher, D. F. 1990, *J. Cell Biol.*, 111, 699.
32. Hocking, D. C., Sottile, J. and McKeown-Longo, P. J. 1994, *J. Biol. Chem.*, 269, 19183.
33. Aguirre, K. M., McCormick, R. J. and Schwarzbauer, J. E. 1994, *J. Biol. Chem.*, 269, 27863.
34. Sottile, J. and Mosher, D. F. 1997, *Biochem. J.*, 323, 51.
35. Ohashi, T., Kiehart, D. P. and Erickson, H. P. 1999, *Proc. Natl. Acad. Sci. USA*, 96, 2153.
36. Smith, M. L., Gourdon, D., Little, W. C., Kubow, K. E., Eguiluz, R. A., Luna-Morris, S. and Vogel, V. 2007, *PLoS Biol.*, 5(e268), 2243.
37. Carraher, C. L. and Schwarzbauer, J. E. 2013, *J. Biol. Chem.*, 288, 14805.
38. Antia, M., Baneyx, G., Kubow, K. E. and Vogel, V. 2008, *Farady Discuss.*, 139, 229.
39. Checovich, W. and Mosher, D. 1993, *Arterioscler. Thromb.*, 13, 1662.
40. Zhang, Q., Checovich, W. J., Peters, D. M., Albrecht, R. M. and Mosher, D. F. 1994, *J. Cell Biol.*, 127, 1447.
41. Zhang, Q., Magnusson, M. K. and Mosher, D. F. 1997, *Mol. Biol. Cell*, 8, 1415.
42. Zhang, Q., Sakai, T., Nowlen, J., Hayashi, I., Fassler, R. and Mosher, D. F. 1999, *J. Biol. Chem.*, 274, 368.
43. Wu, C., Keivens, V. M., O'Toole, T. E., McDonald, J. A. and Ginsberg, M. H. 1995, *Cell*, 83, 715.
44. Baneyx, G., Baugh, L. and Vogel, V. 2002, *Proc. Natl. Acad. Sci. USA*, 99, 14464.
45. Ziad-Bar, R., Cohen, M., Addadi, L. and Geiger, B. 2004, *Biochem. Soc. Trans.*, 32, 416.
46. Zhong, C., Chrzanowska-Wodnicka, M., Brown, J., Shaub, A., Belkin, A. M. and Burridge, K. 1998, *J. Cell Biol.*, 141, 539.
47. Vakonakis, I., Staunton, D., Rooney, L. M. and Campbell, I. D. 2007, *EMBO J.*, 26, 2675.
48. Karuri, N. W., Lin, Z., Rye, H. S. and Schwarzbauer, J. E. 2009, *J. Biol. Chem.*, 284, 3445.
49. Früh, S. M., Schoen, I., Ries, J. and Vogel, V. 2015, *Nat. Commun.*, 6, 7275. doi: 10.1038/ncomms8275.

50. Hocking, D. C., Smith, R. K. and McKeown-Longo, P. J. 1996, *J. Cell Biol.*, 133, 431.
51. Ingham, K. C., Brew, S. A. and Litvinovich, S. V. 1997, *J. Biol. Chem.*, 272, 1718.
52. Gee, E. P., Ingber, D. E. and Stultz, C. M. 2008, *PLoS ONE*, 3, e2373.
53. Gee, E. P., Yuksel, D., Stultz, C. M. and Ingber, D. E. 2013, *J. Biol. Chem.*, 288, 21329.
54. Ohashi, T. and Erickson, H. P. 2005, *J. Biol. Chem.*, 280, 39143.
55. Ohashi, T., Augustus, A. M. and Erickson, H. P. 2009, *Biochemistry*, 48, 4189.
56. Ohashi, T. and Erickson, H. P. 2011, *J. Biol. Chem.*, 286, 39188.
57. Briknarova, K., Akerman, M. E., Hoyt, D. W., Ruoslahti, E. and Ely, K. R. 2003, *J. Mol. Biol.*, 332, 205.
58. Pasqualini, R., Bourdoulous, S., Koivunen, E., Woods, V. L. Jr. and Ruoslahti, E. 1996, *Nat. Med.*, 2, 1197.
59. Yi, M., Sakai, T., Fassler, R. and Ruoslahti, E. 2003, *Proc. Natl. Acad. Sci. USA*, 100, 11435.
60. Bourdoulous, S., Orend, G., MacKenna, D. A., Pasqualini, R. and Ruoslahti, E. 1998, *J. Cell Biol.*, 143, 267.
61. Ambesi, A., Klein, R. M., Pumiglia, K. M. and McKeown-Longo, P. J. 2005, *Cancer Res.*, 65, 148.
62. Ambesi, A. and McKeown-Longo, P. J. 2009, *Mol. Cancer Res.*, 7, 255.
63. Klein, R. M., Zheng, M., Ambesi, A., van de Water, L. and McKeown-Longo, P. J. 2003, *J. Cell Sci.*, 116, 4663.
64. Ambesi, A. and McKeown-Longo, P. J. 2014, *J. Cell Sci.*, 127, 3805.
65. Kong, F., Li, Z., Parks, W. M., Dumbauld, D. W., Garcia, A. J., Mould, A. P., Humphries, M. J. and Zhu, C. 2013, *Mol. Cell*, 49, 1060.
66. Friedland, J. C., Lee, M. H. and Boettiger, D. 2009, *Science*, 323, 642.
67. Schaefer, L. 2014, *J. Biol. Chem.*, 289, 35237.
68. Okamura, Y., Watari, M., Jerud, E. S., Young, D. W., Ishizaka, S. T., Rose, J., Chow, J. C. and Strauss, J. R. 3<sup>rd</sup>. 2001, *J. Biol. Chem.*, 276, 10229.
69. Mogami, H., Kishore, A. H., Shi, H., Keller, P. W., Akgul, Y. and Word, R. A. 2013, *J. Biol. Chem.*, 288, 1953.
70. McFadden, J. P., Basketter, D. A., Dearman, R. J. and Kimber, I. R. 2011, *Clin. Dermatol.*, 29, 257.
71. Kelsh, R., You, R., Horzempa, C., Zheng, M. and McKeown-Longo, P. J. 2014, *PLoS ONE*, 9, e102974. doi: 10.1371/journal.pone.0102974.
72. Bhattacharyya, S., Tamaki, Z., Wang, W., Hinchcliff, M., Hoover, P., Getsios, S., White, E. S. and Varga, J. 2014, *Science Translational Med.*, 6, 232ra50. doi: 10.1126/scitranslmed.3008264.
73. Arslan, F., Smeets, M. B., Riem Vis, P. W., Karper, J. C., Quax, P. H., Bongartz, L. G., Peters, J. H., Hoefler, I. E., Doevendans, P. A., Pasterkamp, G. and de Kleijn, D. P. 2011, *Circ. Res.*, 108, 582.
74. Booth, A. J., Wood, S. C., Cornett, A. M., Dreffs, A. A., Lu, G., Muro, A. F., White, E. S. and Bishop, D. K. 2012, *J. Pathol.*, 226, 609.
75. Kohan, M., Muro, A. F., Bader, R. and Berkman, N. 2011, *J. Allergy Clin. Immunol.*, 127, 439.
76. Muro, A. F., Moretti, F. A., Moore, B. B., Yan, M., Atrasz, R. G., Wilke, C. A., Flaherty, K. R., Martinez, F. J., Tsui, J. L., Sheppard, D., Baralle, F. E., Toews, G. G. and White, E. S. 2008, *Am. J. Resp. Crit. Care Med.*, 177, 638.
77. You, R., Zheng, M. and McKeown-Longo, P. J. 2010, *J. Biol. Chem.*, 285, 36255.
78. Zheng, M., Jones, D. M., Horzempa, C., Prasad, A. and McKeown-Longo, P. M. 2011, *J. Cancer*, 2, 478.
79. Castell, J. V., Guillén, M. I., Marco, V., Menendez, R., Nauffal, D. and Gómez-Lechón, M. J. 1988, *Biochem. Soc. Trans.*, 16, 378.
80. Wysocki, A. B. and Grinnell, F. 1990, *Lab. Invest.*, 63, 825.
81. Xie, D. L., Meyers, R. and Homandberg, G. A. 1992, *J. Rheumatol.*, 19, 1448.
82. Huynh, Q. N., Wang, S., Tafolla, E., Gansky, S. A., Kapila, S., Armitage, G. C. and Kapila, Y. L. 2002, *J. Periodontol.*, 73, 1101.
83. Stanley, C. M., Wang, Y., Pal, S., Klebe, R. J., Harkless, L. B., Xu, X., Chen, Z. and Steffensen, B. 2008, *J. Periodontol.*, 79, 861.

- 
84. Sofat, N. 2009, *Int. J. Exp. Pathol.*, 90, 463.
  85. Doucet, A. and Overall, C. M. 2011, *Mol. Cell Proteomics*, 10, M110.003533.
  86. Bradshaw, M. J., Cheung, M. C., Ehrlich, D. J. and Smith, M. L. 2012, *PLoS Comput. Biol.*, 8, e1002845. doi:10.1371/journal.pcbi1002845. Epub. 2012 Dec 27.
  87. Harris, G., Ma, W., Maurer, L. M., Potts, J. R. and Mohser, D. F. 2014, *J. Biol. Chem.*, 289, 22490.
  88. Prabhakaran, S., Liang, X., Skare, J. T., Potts, J. R. and Höök, M. 2009, *PLoS ONE*, 4, e5412.
  89. Akerman, M. E., Pilch, J., Peters, D. and Ruoslahti, E. 2005, *Proc. Natl. Acad. Sci. USA*, 102, 2040.
  90. Zoppi, N., Ritelli, M. and Colombi, M. 2012, *Biochim. et Biophys. Acta*, 1820, 1576.
  91. Kelsh, R. M., McKeown-Longo, P. J. and Clark, R. A. F. 2015, *J. Invest. Dermatol.*, 135, 1714.